

SHALLCO SERIES 26
Part Number: 26206D



General:

Meets requirements for 1 - 25 ampere switching of resistive loads to .75 power factor at voltages to 600 V AC and 250 V DC resistive loads

Electrical Ratings: 25A/120 VAC
 15A/600 VAC
 20A/600 VAC (RES)
 3A/125 VDC
 1A/250 VDC

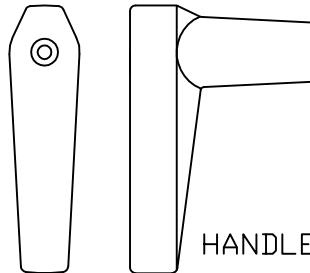

- * Current carrying capacity: 25 amperes
- * Dielectric Withstanding Voltage: 2200 Vrms
- * Contact Resistance: Initial, 10 milliohms max.
- * Insulation Resistance: 100 Megohms min., initial

Mechanical:

- * Sections: 6
- * Positions: 8 Adjustable (See Truth Table)
- * Indexing: 45° positive detent
- * Rotational Life: 65,000 operations

Materials and Finishes:

- * Rotors and Stators: Thermoset Plastic
 UL 94VO
- * Rotor contacts: Phosphor bronze
- * Stator contacts: Silver plated copper
 screw type
- * Terminal hardware: silver plated brass
- * Exterior Metal: Steel with zinc chromate finish

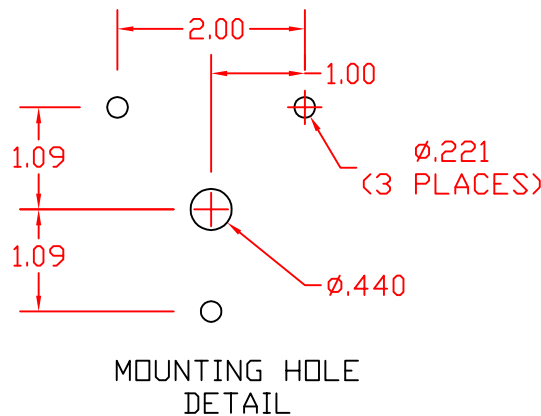

CONTACT TABLE

DECK	CONTACTS	POSITION							
		1	2	3	4	5	6	7	8
1	11								
	12								
	13								
	14								
	15								
	16								
	17								
	18								
2	21								
	22								
	23								
	24								
	25								
	26								
	27								
	28								
3	31								
	32								
	33								
	34								
	35								
	36								
	37								
	38								
4	41								
	42								
	43								
	44								
	45								
	46								
	47								
	48								
5	51								
	52								
	53								
	54								
	55								
	56								
	57								
	58								
6	61								
	62								
	63								
	64								
	65								
	66								
	67								
	68								

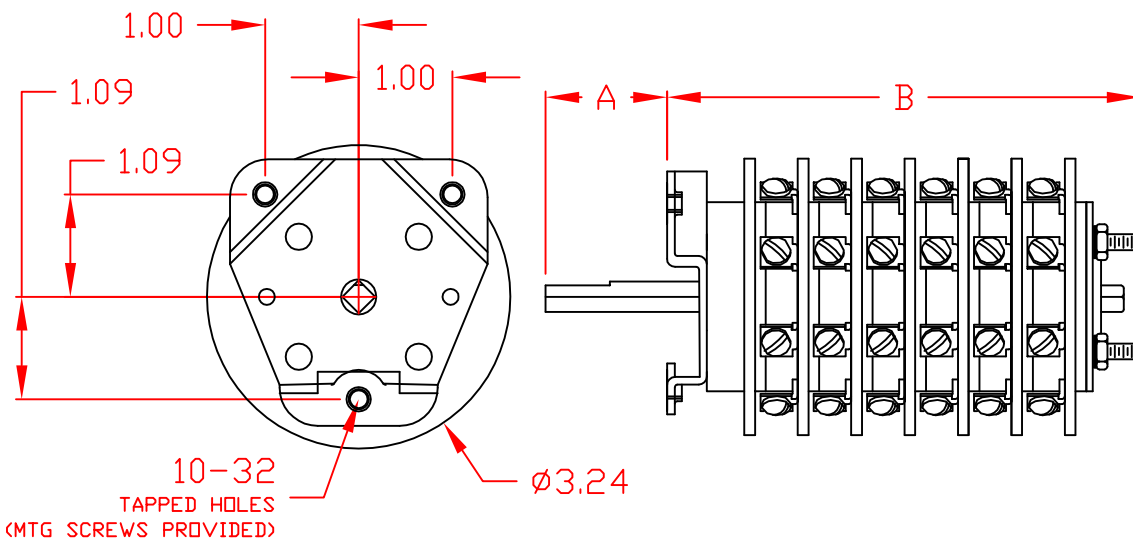

26206D

HANDLE TYPE: B (OVAL)

"A" DIM: 1.61

"B" DIM: 5.41



308 COMPONENTS DRIVE
 SMITHFIELD, NC 27577 USA

REV. B