

SHALLCO SERIES 26

Part Number: 76803D



General:

Meets requirements for 1 - 25 ampere switching of resistive loads to .75 power factor at voltages to 600 V AC and 250 V DC resistive loads

Electrical:

* Ratings:

25A/120 VAC

15A/600 VAC

20A/600 VAC (RESISTIVE)

3A/125 VDC

1A/250 VDC



- * Current carrying capacity: 25 amperes
- * Dielectric Withstanding Voltage: 2200 Vrms
- * Contact Resistance: Initial, 10 milliohms max.
- * Insulation Resistance: 100 Megohms min., initial

Mechanical:

- * Sections: 3
- * Positions: 3, Spring return to position 1
- * Indexing: 45°
- * Rotational Life: 65,000 operations

Materials and Finishes:

- * Rotors and Stators: Thermoset Plastic, UL 94VO
- * Rotor contacts: Phosphor bronze
- * Stator contacts: Silver plated copper, screw type
- * Terminal hardware: silver plated brass
- * Exterior Metal: Steel with zinc chromate finish
- * Knob: thermoset phenolic

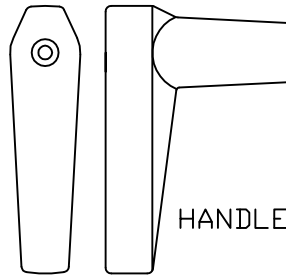

HANDLE

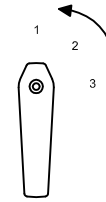

DECK	CONTACTS	POSITIONS		
		1	2	3
1	11-12	X		
	11-13		X	
	11-14			X
	11-16	X		
	11-17		X	
	11-18			X
2	21-22	X		
	21-23		X	
	21-24			X
	21-26	X		
	21-27		X	
	21-28			X
3	31-32	X		
	31-33		X	
	31-34			X
	31-36	X		
	31-37		X	
	31-38			X

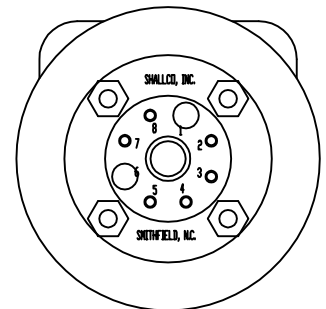
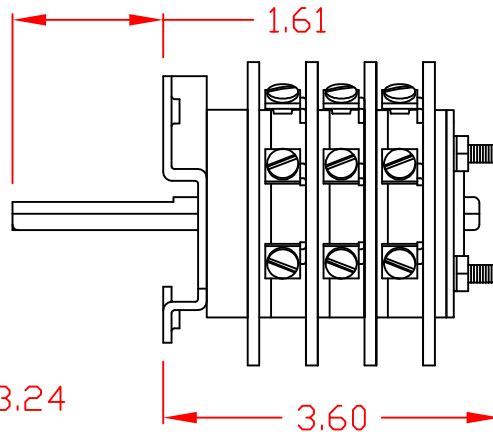
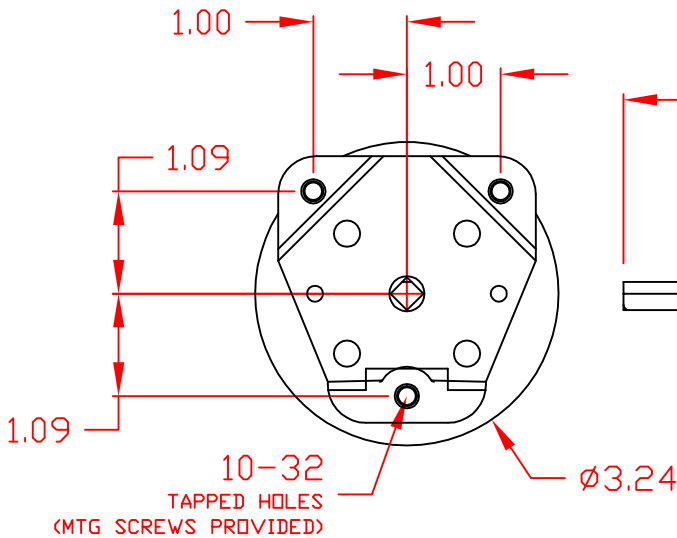
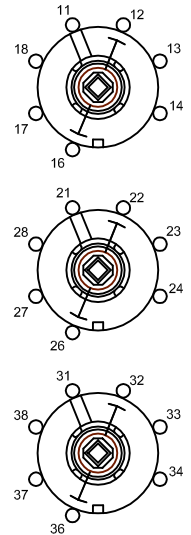

DESCRIPTION

76803D



308 COMPONENTS DRIVE
SMITHFIELD, NC 27577 USA

TERMINAL SCREW TIGHTENING TORQUE: : 8 IN-LBS.