

**SHALLCO SERIES 26**  
**Part Number: 26308C**



**General:**

Meets requirements for 1 - 25 ampere switching of resistive loads to .75 power factor at voltages to 600 V AC and 250 V DC resistive loads

**Electrical Ratings:** 25A/120 VAC  
 15A/600 VAC  
 20A/600 VAC (RES)  
 3A/125 VDC  
 1A/250 VDC



- \* Current carrying capacity: 25 amperes
- \* Dielectric Withstanding Voltage: 2200 Vrms
- \* Contact Resistance: Initial, 10 milliohms max.
- \* Insulation Resistance: 100 Megohms min., initial

**Mechanical:**

- \* Sections: 8
- \* Positions: 8 Adjustable (See Truth Table)
- \* Indexing: 45° positive detent
- \* Rotational Life: 65,000 operations

**Materials and Finishes:**

- \* Rotors and Stators: Thermoset Plastic  
 UL 94V0
- \* Rotor contacts: Phosphor bronze
- \* Stator contacts: Silver plated copper screw type
- \* Terminal hardware: silver plated brass
- \* Exterior Metal: Steel with zinc chromate finish

DECK	CONTACTS	POSITIONS							DECK	CONTACTS	POSITIONS							
		OFF	1	2	3	4	5	6			7	OFF	1	2	3	4	5	6
1	110			X					5	510		X						
					X								X					
						X								X				
							X								X			
								X								X		
										X								X
2	210		X						6	610		X						
				X								X						
					X								X					
						X								X				
							X								X			
								X								X		
3	310		X						7	710		X						
				X								X						
					X								X					
						X								X				
							X								X			
								X								X		
4	410		X						8	810		X						
				X								X						
					X								X					
						X								X				
							X								X			
								X								X		

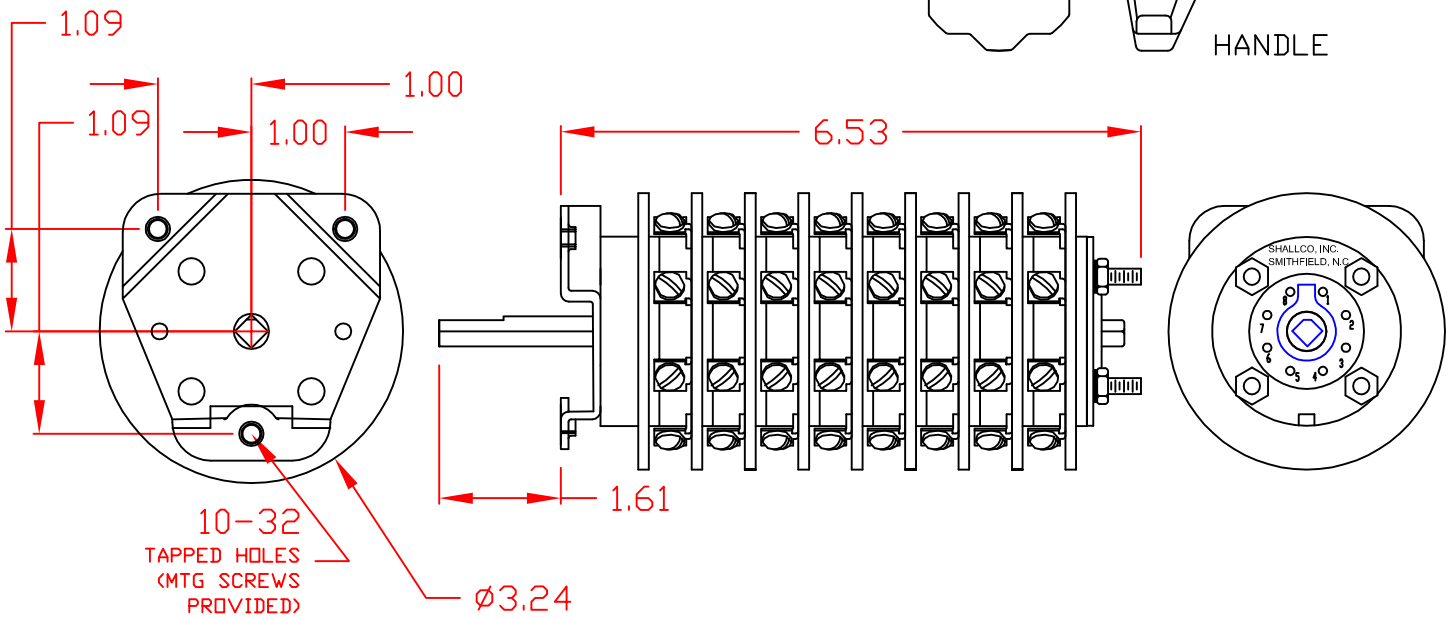
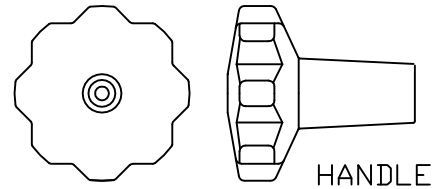

26308C

REV. -



308 COMPONENTS DRIVE  
 SMITHFIELD, NC 27577 USA

TERMINAL SCREW TIGHTENING TORQUE: 8 IN.-LBS.