

**SPECIFICATIONS:**

NO. OF POSITIONS: 2, TRIP AND RESET

NO. OF SECTIONS: 2

CONTACTS: 2 NORMALLY OPEN  
2 NORMALLY CLOSED  
PER DECK

ACTION: 45° POSITIVE TRIP DETENT

STATIONARY CONTACTS : SILVER OVER COPPER

NAMEPLATE: AS SHOWN

**COIL SPECIFICATIONS:**

OPERATING VOLTAGE: 125 VDC / 120 VAC

THRESHOLD VOLTAGE: 16 VDC / 20 VAC

OPERATING RANGE: 30 - 140 VDC / 30 - 140 VAC

CURRENT AT RATED VOLTAGE: 4.6 / 4.4 AMPS

DECK	CONTACTS	POSITION	
		TRIP	RESET
1	11 —  —  — 13		X
	12 —  —  — 18	X	
	15 —  —  — 17		X
	16 —  —  — 14	X	
2	21 —  —  — 23		X
	22 —  —  — 28	X	
	25 —  —  — 27		X
	26 —  —  — 24	X	

**ELECTRICAL RATINGS:**

25A/120 VAC

15A/600 VAC

20A/600 VAC (RESISTIVE)

3A/125 VDC

1A/250 VDC



**OVERLOAD CURRENT (50 OPERATIONS):**

95 A/120 VAC

65 A/240 VAC

35 A/600 VAC

DIELECTRIC STRENGTH: 2200 VRMS

INSULATION RESISTANCE: 100 MEGOHMS INITIAL

CONTACT RESISTANCE: 10 MILLIOHMS MAX. INITIAL

**NAMEPLATE AND PANEL DRILLING DIMENSIONS**

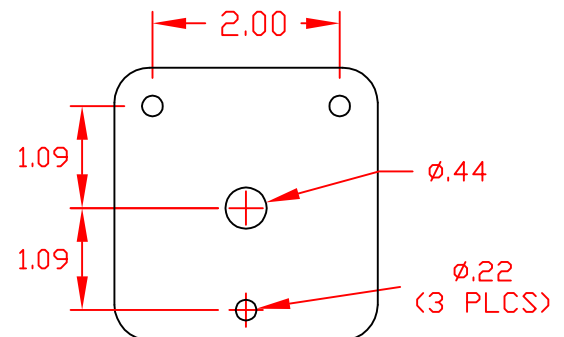

LOCK-OUT RELAYS (LOR)

GENERAL OPERATION:

THE HANDLE OF THE LOR MUST BE MANUALLY ROTATED CLOCKWISE TO PLACE THE UNIT IN THE "RESET" POSITION (SEE FIGURE A)

FIGURE A - RESET POSITION

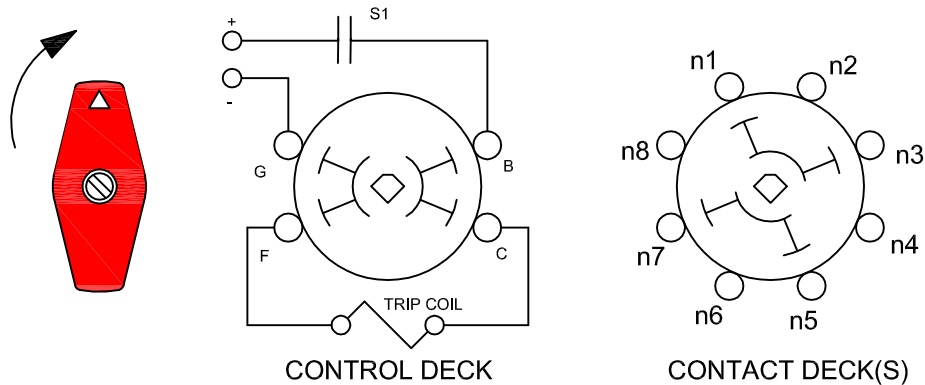

WHEN A PREDETERMINED CONDITION EXISTS, A SIGNAL WILL BE SENT TO S1 WHICH WILL ACTIVATE THE COIL AND CAUSE THE LOR TO "TRIP". THE "B" AND "G" CONTACTS ON THE CONTROL DECK PROVIDE THE CONNECTION TO THE CONTROL CIRCUIT THROUGH S1 WHICH CAN BE A CONTACT OF ANY TYPE I.E. SWITCH, RELAY.... THE LOR CONTACTS IN FIGURE "B" ARE IN THE "TRIPPED" POSITION.

THE LOR WILL REMAIN IN THE "TRIPPED" POSITION UNTIL MANUALLY RESET.

FIGURE B - TRIP POSITION

