

SHALLCO SERIES 16 SWITCH

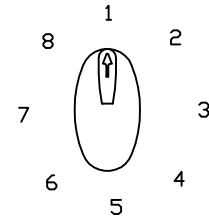

PART NO: 16C4-B-1-B

NO. OF SECTIONS: 1
 INDEXING: 45°
 CIRCUIT: C (SEE TRUTH TABLE)
 TYPE ACTION: NONSHORTING
 DETENT: STANDARD
 STOPS INSTALLED: NO
 TERMINALS: SCREW TYPE, HARDWARE SUPPLIED
 PHENOLIC POINTER KNOB: SUPPLIED
 MOUNTING HARDWARE: SUPPLIED



ELECTRICAL RATINGS:

- 15 A @ 125 VAC
- 5 A @ 250 VAC
- 3 A @ 600 VAC
- 5 A @ 30 VDC
- 1 A @ 125 VDC



DECK	CONTACTS	POSITION							
		1	2	3	4	5	6	7	8
1	11								
	12		X						
	13			X					
	14				X				
	15					X			
	16						X		
	17							X	
18								X	

"X" DENOTES CONTACT CLOSURE

DIELECTRIC WITHSTANDING VOLTAGE: 1500 VRMS
 CONTACT RESISTANCE: 10 MILLIOHMS MAX. INITIAL
 INSULATION RESISTANCE: 1000 MEGHOHMS, INITIAL

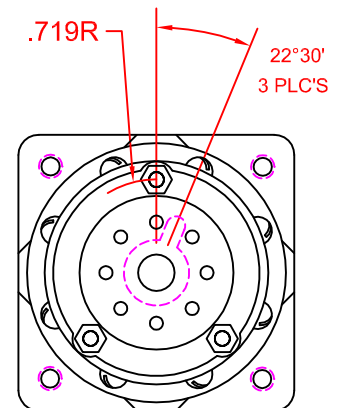
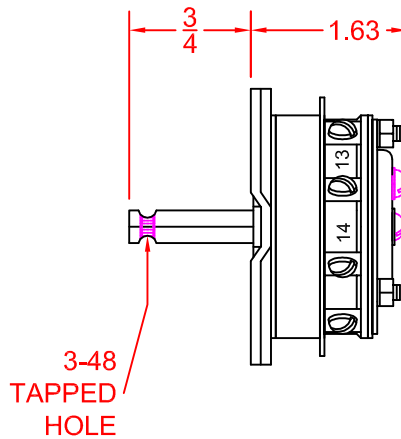
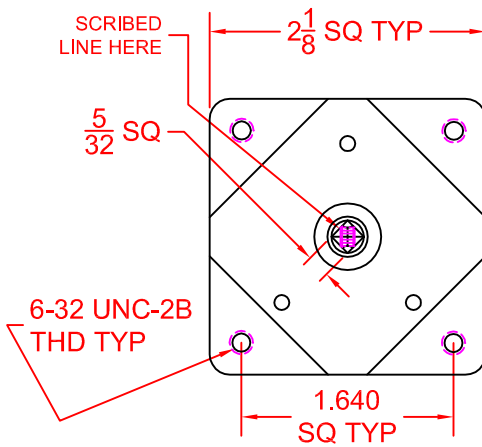
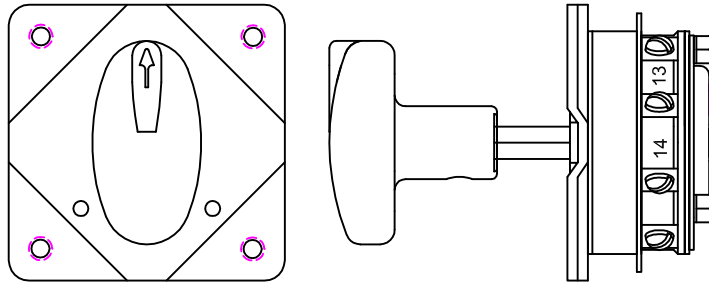

DESCRIPTION

16A4-B-1-B

REV A



308 COMPONENTS DRIVE
 SMITHFIELD, NC 27577 USA