

SHALCO SERIES 26

Part Number: 2658D 120VACABC

Description: **BREAKER CONTROL SWITCH**
With Lighted Nameplate (120 VAC)

General: Meets requirements for 1 - 25 ampere switching of resistive loads to .75 power factor at voltages to 600 V AC and 250 VDC resistive loads

Electrical:

- * Ratings: 25A/120 VAC
15A/600 VAC
20A/600 VAC (RESISTIVE)
3A/125 VDC
1A/250 VDC
- * Current carrying capacity: 25 amperes
- * Dielectric Withstanding Voltage: 2200 Vrms
- * Contact Resistance: Initial, 10 milliohms max.
- * Insulation Resistance: 100 Megohms min., Initial

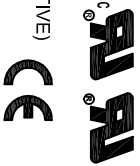

Mechanical:

- * Sections: 6
- * Positions: See contact table
- * Dentil type: Decks 1 - 4 spring return with Pull to Lock in extreme counter-clockwise position. Decks 5 and 6 detented slip contacts
- * Indexing: 45°
- * Rotational Life: 65,000 operations

Materials and Finishes:

- * Rotors and Stators: Thermoset Plastic, UL 94V0
- * Rotor contacts: Phosphor bronze
- * Stator contacts: Silver plated copper, screw type
- * Terminal hardware: silver plated brass
- * Exterior Metal: Steel with zinc chromate finish
- * Knob: Thermoset phenolic

LIGHTED NAMEPLATE
(WIRE LENGTHS APPROX 20 INCHES)

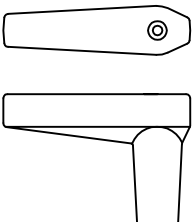
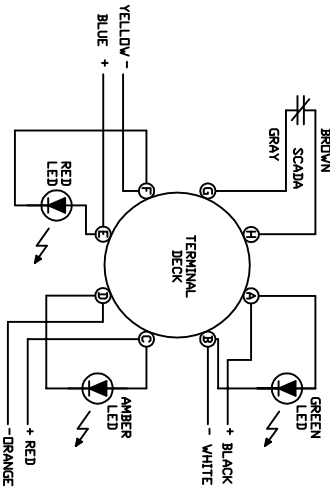
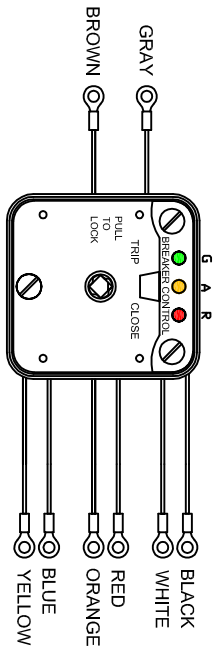

DECK	CONTACTS	POSITIONS		
		PULL-TL	TRIP	nat nac CLOSE
1	120-1-1-013 160-1-1-017			X
2	210-1-1-028	X		X
3	240-1-1-025	X		
4	330-1-1-034 370-1-1-038	X		
5	410-1-1-042 450-1-1-046 520-1-1-053	X	X	X
6	560-1-1-057 610-1-1-062 650-1-1-066	X	X	X

CONTACT TABLE

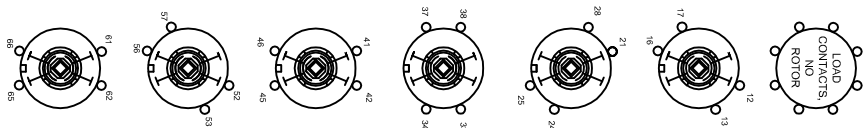
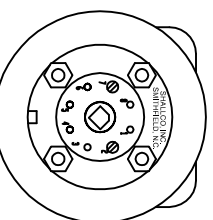
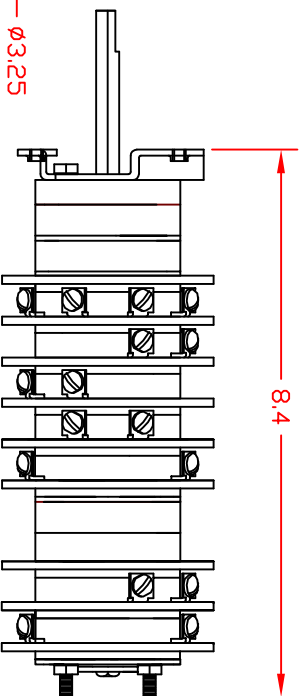
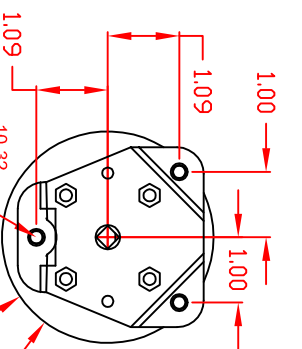
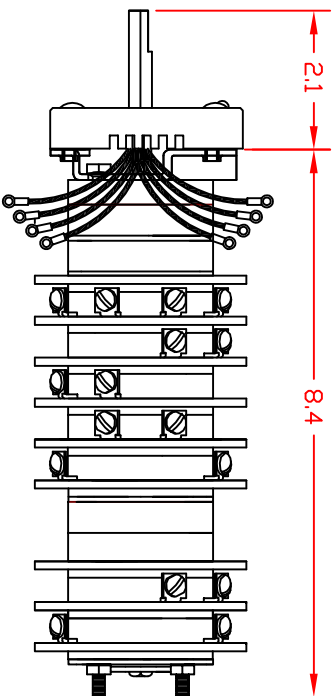
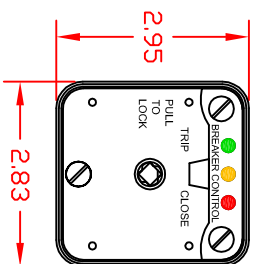
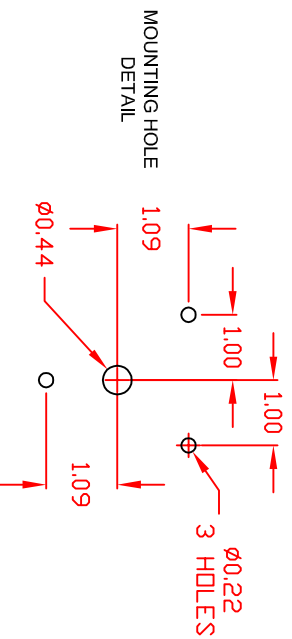

2658D 120VACABC

