

SHALLCO SERIES 26
Part Number: 26901B-2



Electrical:

- * Ratings:
- 25A/120 VAC
- 15A/600 VAC
- 20A/600 VAC (RESISTIVE)
- 3A/125 VDC
- 1A/250 VDC



Overload (50 OPERATIONS):

- 95A/120VAC
- 65A/240VAC
- 35A/600VAC

DECK	CONTACTS	POSITION	
		1	2
1	11 o o 13	X	
	12 o o 14		X
	15 o o 17	X	
	16 o o 18		X

CONTACT TABLE

- * Current carrying capacity: 30 amperes
- * Dielectric Withstanding Voltage: 2200 Vrms
- * Contact Resistance: Initial, 10 milliohms max.
- * Insulation Resistance: 100 Megohms min., initial

Mechanical:

- * Sections: 1
- * Positions: 2
- * Type of switching: Non-Shorting
- * Indexing: 45°
- * Rotational Life: 65,000 operations

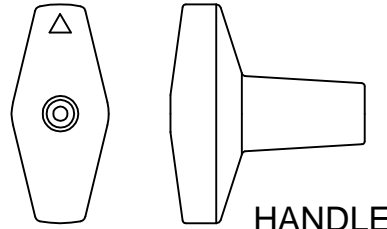

HANDLE

STATOR DIAGRAM

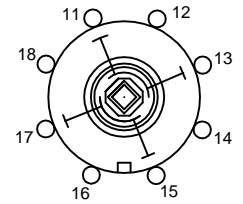

Materials and Finishes:

- * Rotors and Stators: Thermoset Plastic, UL 94VO
- * Rotor contacts: Phosphor bronze
- * Stator contacts: Silver plated copper, screw type
- * Terminal hardware: silver plated brass
- * Exterior Metal: Steel with zinc chromate finish
- * Knob: thermoset phenolic

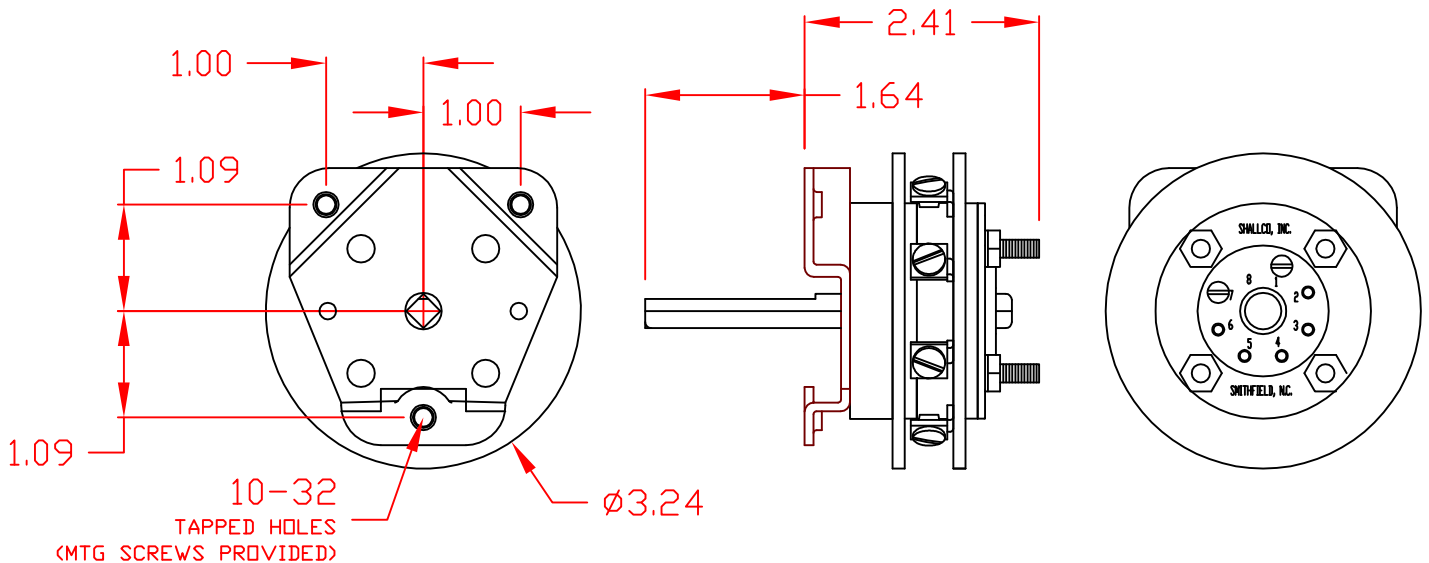

DESCRIPTION	26901B-2	REV. -
-------------	-----------------	--------



308 COMPONENTS DRIVE
 SMITHFIELD, NC 27577 USA