

REVISIONS

LTR	DESCRIPTION	DATE	APP'D
-----	-------------	------	-------

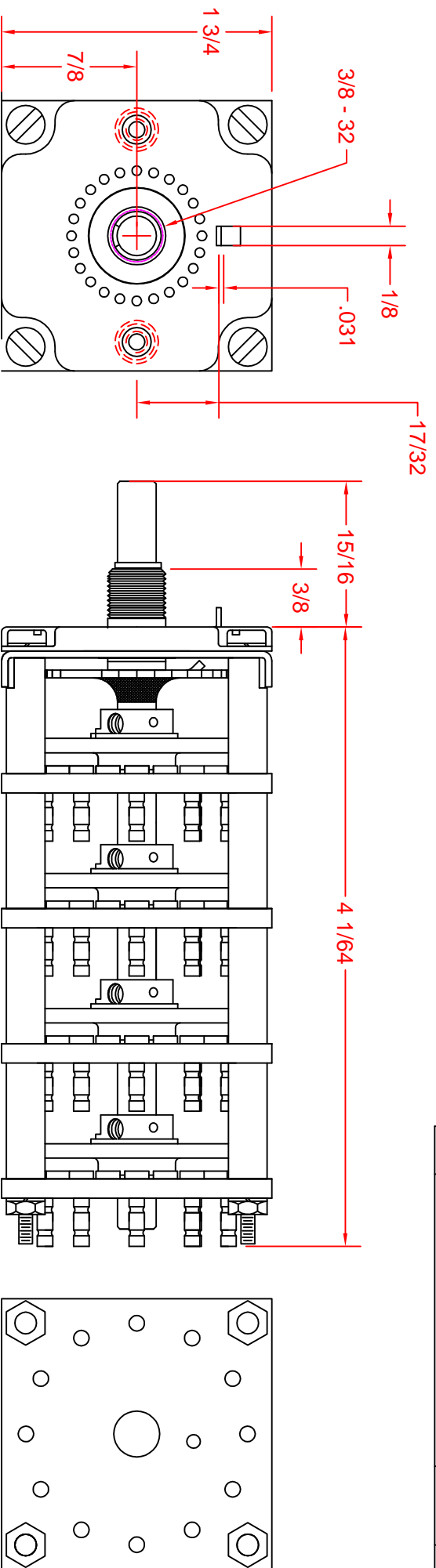

DESCRIPTION

SHALLCO PART NUMBER: 411-CB-12-375  
 NUMBER OF DECKS: 4  
 NUMBER OF POLES PER DECK: 1  
 NUMBER OF POSITIONS: 12 (adjustable)  
 DETENT: STANDARD  
 ANGLE BETWEEN CONTACTS: 30°

SWITCHING: NONSHORTING  
 CURRENT CARRYING CAPACITY: 10 AMPERES  
 CURRENT SWITCHING CAPACITY: 2 AMPERES  
 CONTACT RESISTANCE, INITIAL: 5 MILLIOHMS MAX.  
 CONTACT RESISTANCE, AFTER LIFE: 10 MILLIOHMS MAX.  
 INSULATION RESISTANCE: 50,000 MEGOHMS  
 DIELECTRIC WITHSTANDING VOLTAGE: 1500 VRMS  
 DIELECTRIC WITHSTANDING VOLTAGE, AFTER LIFE: 1000 VRMS  
 ROTATIONAL LIFE: 50,000 CYCLES (ONE CYCLE = ONE FULL  
 CLOCKWISE AND ONE FULL COUNTER CLOCKWISE ROTATION)

DESCRIPTION

411-CB-12-375

REV. -



308 COMPONENTS DRIVE  
 SMITHFIELD, NC 27577  
 USA