

SHALLCO SERIES 26

Part Number: 2636B



General:

Meets requirements for 1 - 25 ampere switching of resistive loads to .75 power factor at voltages to 600 V AC and 250 VDC resistive loads

Electrical:

* Ratings:



- 25A/120 VAC
- 15A/600 VAC
- 20A/600 VAC (RESISTIVE)
- 3A/125 VDC
- 1A/250 VDC

- * Current carrying capacity: 25 amperes
- * Dielectric Withstanding Voltage: 2200 Vrms
- * Contact Resistance: Initial, 10 milliohms max.
- * Insulation Resistance: 100 Megohms min., initial

Mechanical:

- * Sections: 1
- * Positions: 2, Spring Return CCW
- * Indexing: 45°
- * Rotational Life: 65,000 operations

Materials and Finishes:

- * Rotors and Stators: Thermoset Plastic, UL 94VO
- * Rotor contacts: Phosphor bronze
- * Stator contacts: Silver plated copper, screw type
- * Terminal hardware: silver plated brass
- * Exterior Metal: Steel with zinc chromate finish
- * Knob: thermoset phenolic

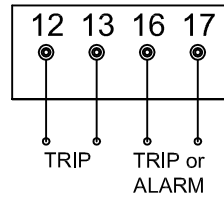

DECK	CONTACTS		POS	
	NORMAL	TRIP	NORMAL	TRIP
1	12	13		X
	16	17		X

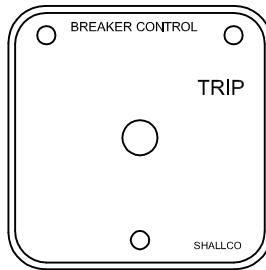

ESCUTCHEON PLATE

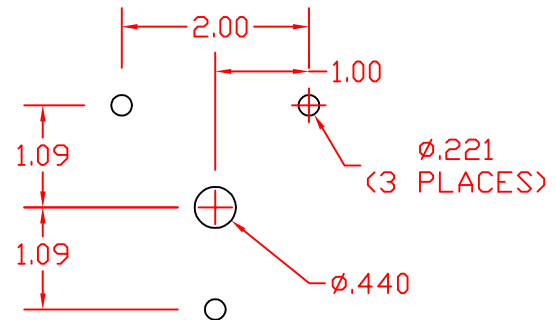
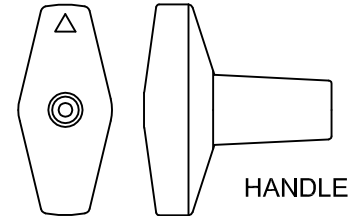

MOUNTING HOLE
DETAIL

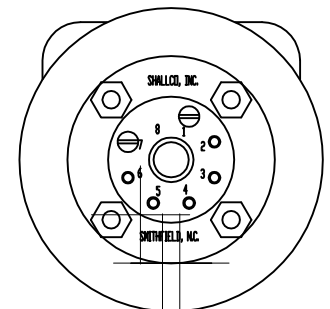
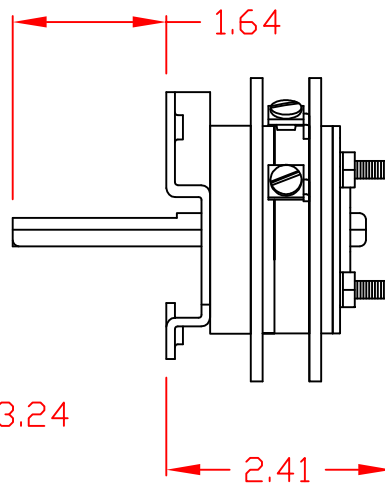
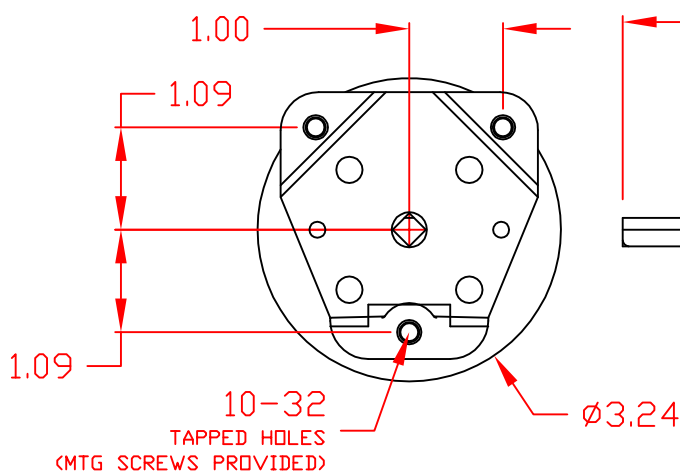

DESCRIPTION

2636B



308 COMPONENTS DRIVE
SMITHFIELD, NC 27577 USA

REV. -