

SHALLCO SERIES 26

Part Number: 2604C

VOLTMETER TRANSFER SWITCH

3-phase, phase-to-phase



308 COMPONENTS DRIVE
SMITHFIELD, NC 27577 USA

General:

Meets requirements for 1 - 25 ampere switching of resistive loads to .75 power factor at voltages to 600 V AC and 250 V DC resistive loads

Electrical:

- * Ratings: 25A/120 VAC
- 15A/600 VAC
- 20A/600 VAC (RESISTIVE)
- 3A/125 VDC
- 1A/250 VDC



- * Current carrying capacity: 25 amperes
- * Dielectric Withstanding Voltage: 2200 Vrms
- * Contact Resistance: Initial, 10 milliohms max.
- * Insulation Resistance: 100 Megohms min., initial

Mechanical:

- * Sections: 2
- * Positions: 4 See Schematic Diagram
- * Indexing: 45°
- * Rotational Life: 65,000 operations

Materials and Finishes:

- * Rotors and Stators: Thermoset Plastic, UL 94VO
- * Rotor contacts: Phosphor bronze
- * Stator contacts: Silver plated copper, screw type
- * Terminal hardware: silver plated brass
- * Exterior Metal: Steel with zinc chromate finish
- * Knob: thermoset phenolic

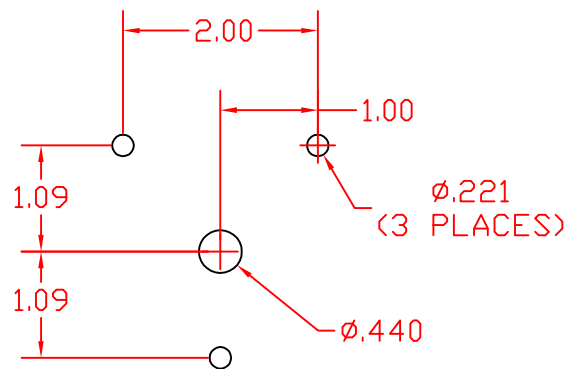

MOUNTING HOLE DETAIL

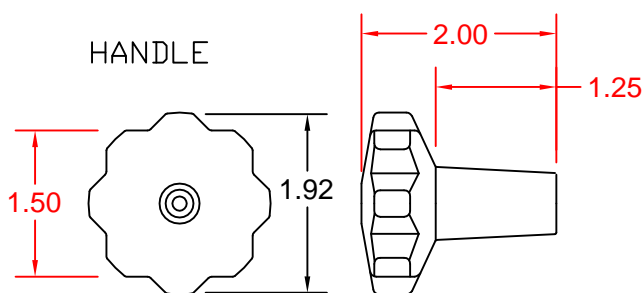

DECK	CONTACTS	POSITIONS			
		OFF	1-2	2-3	3-1
1	11-O		X		
	11-O12			X	
	11-O13				X
2	21-O				X
	11-O22	X			
	11-O23		X		
	11-O24			X	

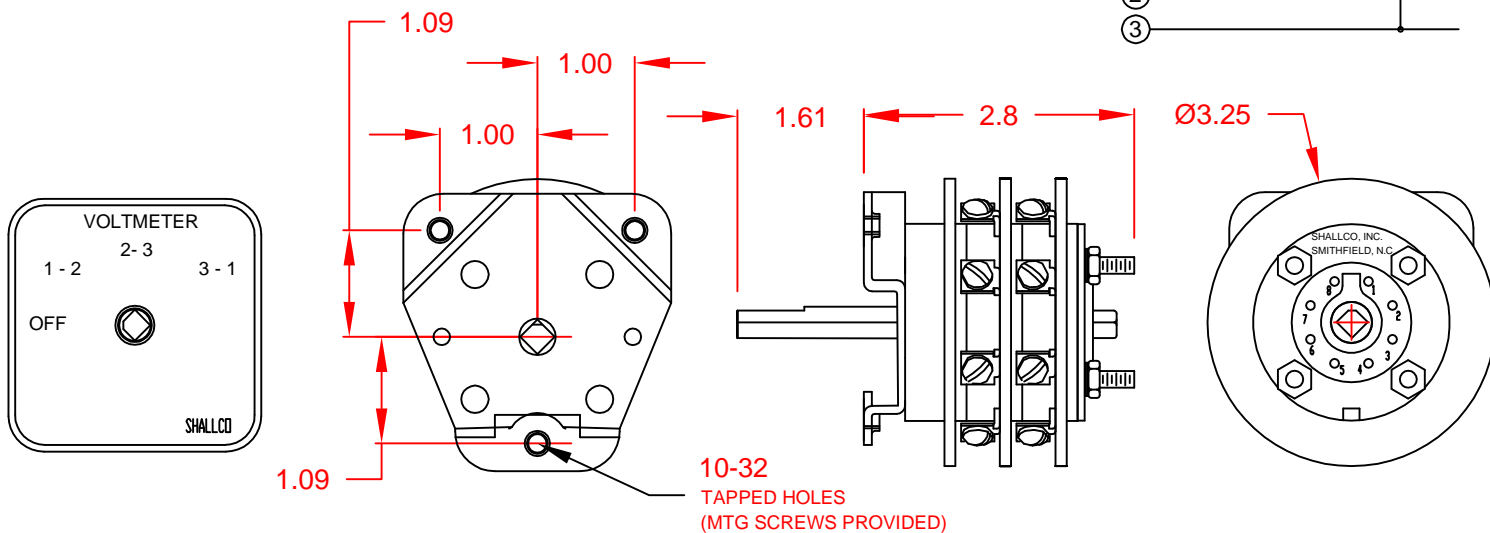
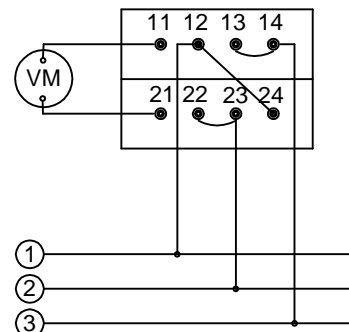

2604C

REV. B



308 COMPONENTS DRIVE
SMITHFIELD, NC 27577 USA