

SHALLCO SERIES 16 KEYLOCK SWITCH



PART NO: 16D2-M-2-1

DESCRIPTION:

NO. OF SECTIONS: 2
 NO. OF POSITIONS: 8 ADJUSTABLE
 KEY REMOVABLE: VERTICAL POSITION ONLY
 INDEXING: 45°
 CIRCUIT: D (SEE CONTACT TABLE AND STATOR DIAGRAM)
 TYPE ACTION: SHORTING
 DETENT: STANDARD
 STOPS INSTALLED: NO
 TERMINALS: SCREW TYPE, HARDWARE SUPPLIED
 MOUNTING HARDWARE: SUPPLIED

ELECTRICAL RATINGS:

- 15 A @ 125 VAC
- 5 A @ 250 VAC
- 3 A @ 600 VAC
- 5 A @ 30 VDC
- 1 A @ 125 VDC



DIELECTRIC WITHSTANDING VOLTAGE: 1500 VRMS
 CONTACT RESISTANCE: 10 MILLIOHMS MAX. INITIAL
 INSULATION RESISTANCE: 1000 MEGHOHMS, INITIAL

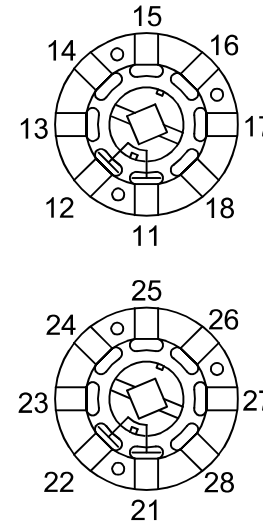
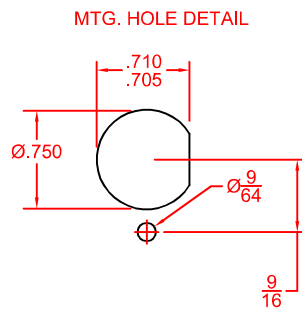

CONTACT TABLE

DECK	CONTACTS	POSITION							
		1	2	3	4	5	6	7	8
1	11		X						
	12			X					
	13				X				
	14					X			
	15						X		
	16							X	
	17								X
	18								
2	21	X							
	22		X						
	23			X					
	24				X				
	25					X			
	26						X		
	27							X	
	28								X

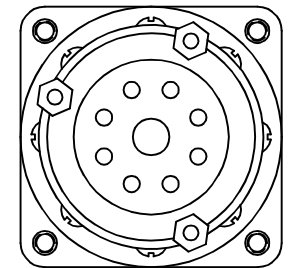
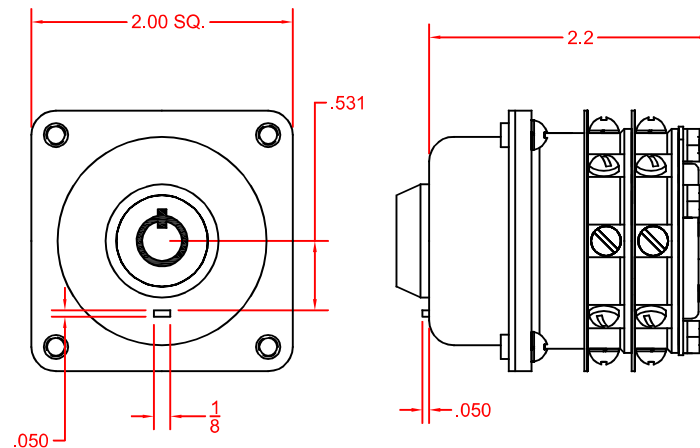

DESCRIPTION	16D2-M-2-1
308 COMPONENTS DRIVE SMITHFIELD, NC 27577 USA	