

SHALLCO SERIES 16 SWITCH

PART NO: 16A1-B-4

NO. OF SECTIONS: 4
 INDEXING: 45°
 CIRCUIT: A (SEE DIAGRAMS)
 TYPE ACTION: NONSHORTING
 DETENT: STANDARD
 STOPS INSTALLED: NO
 TERMINALS: SCREW TYPE, HARDWARE SUPPLIED
 PHENOLIC POINTER KNOB: SUPPLIED
 MOUNTING HARDWARE: SUPPLIED

ELECTRICAL RATINGS:

- 15 A @ 125 VAC
- 5 A @ 250 VAC
- 3 A @ 600 VAC
- 5 A @ 30 VDC
- 1 A @ 125 VDC



DIELECTRIC WITHSTANDING VOLTAGE: 1500 VRMS
 CONTACT RESISTANCE: 10 MILLIOHMS MAX. INITIAL
 INSULATION RESISTANCE: 1000 MEGHOHMS, INITIAL

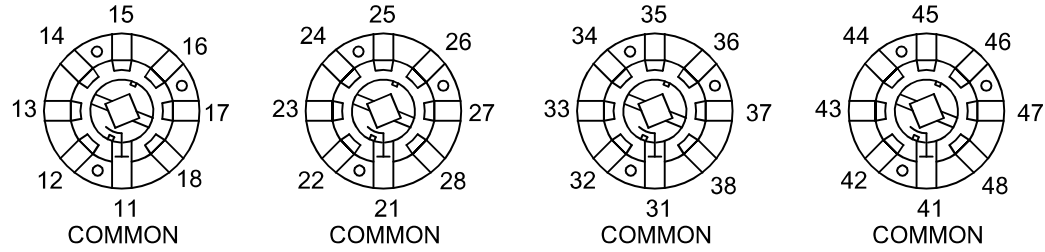

SCHEMATIC DIAGRAM

CIRCUIT "A"

COMMONS LOCATED AT TERMINALS 11, 21, 31 & 41
 (SWITCH SHOWN IN THE "OFF" POSITION)

DECK	CONTACTS	POSITION							
		1	2	3	4	5	6	7	8
1	11								
	12		X						
	13			X					
	14				X				
	15					X			
	16						X		
	17							X	
	18								X
2	21								
	22		X						
	23			X					
	24				X				
	25					X			
	26						X		
	27							X	
	28								X
3	31								
	32		X						
	33			X					
	34				X				
	35					X			
	36						X		
	37							X	
	38								X
4	41								
	42		X						
	43			X					
	44				X				
	45					X			
	46						X		
	47							X	
	48								X

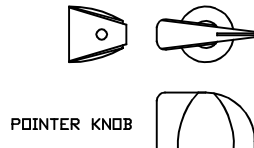

POINTER KNOB

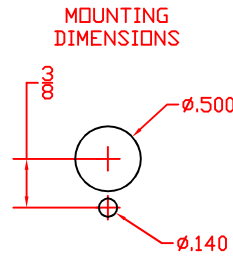

MOUNTING DIMENSIONS

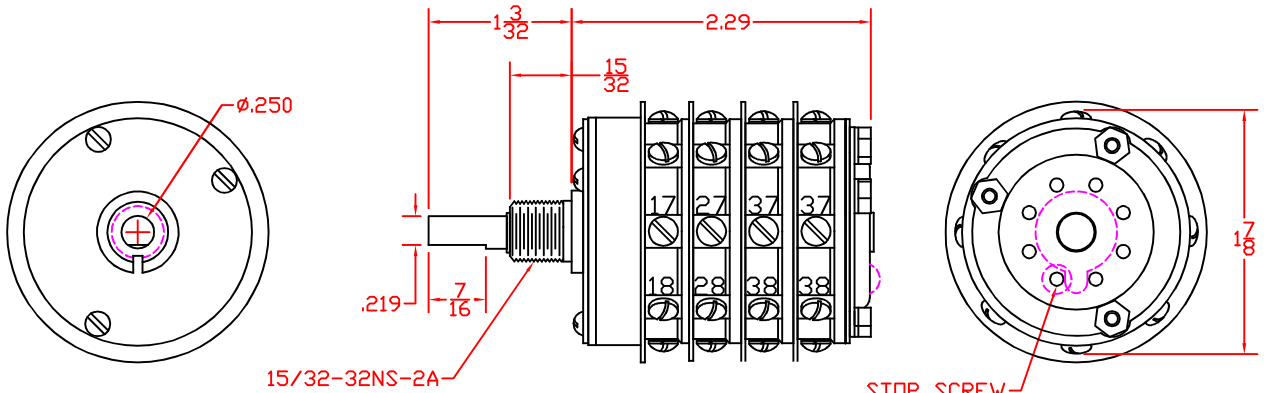

15/32-32NS-2A

STOP SCREW

DESCRIPTION	16A1-B-4
308 COMPONENTS DRIVE SMITHFIELD, NC 27577 USA	